

Owner's Manual

Parts Manual

**READ THIS MANUAL CAREFULLY
IT CONTAINS IMPORTANT SAFETY INFORMATION**

**MINIMUM
RECOMMENDED
OPERATOR AGE: 13+**



This operation manual is made for Go-kart models:

**MID XRX、 MID XRS、 TBM80、 GK80、 GK196、
MID GK-1、 MID GK-2**

FOR OFF-ROAD USE ONLY

This vehicle is designed and manufactured for off-road use only.
USA only:

It does not conform to Federal Motor Vehicle Safety Standards, and in regards to operation on public streets, roads or highways is illegal.



BV Powersports, LLC – EMISSION CONTROL SYSTEM WARRANTY

YOUR WARRANTY RIGHTS AND OBLIGATIONS

The California Air Resources Board, the U.S. Environmental Protection Agency, and BV Powersports LLC (hereinafter “distributor”) are pleased to explain the emission control system warranty on your 2011 Off-Road ATV.

New off-road motor vehicles must be designed, built and equipped to meet U.S. EPA Federal and California anti-smog standards. Distributor must warrant the emission control system on your vehicle for 5,000 km, 500 hours of engine operation, or at least 30 months, whichever comes first, provided that there has been no abuse, neglect or improper maintenance of your vehicle. This ATV was designed to meet the emission standards for 10,000 km, 1,000 hours of engine operation, or five years, whichever comes first.

Your emission control system may include parts such as the carburetor or fuel injection system, the ignition system, catalytic converter and engine computer, if it is equipped. Also included may be hoses, belts, connectors and other emission-related assemblies.

This vehicle is warranted, for its emission control devices, for the full useful life of the vehicle. Where a warrantable condition exists, Distributor will repair your vehicle at no cost to you, including diagnosis, parts and labor.

If an emission-related part on your vehicle is defective, the part will be repaired or replaced by distributor. This is your emission control system DEFECTS WARRANTY.

OWNER’S WARRANTY RESPONSIBILITIES

As the vehicle owner, you are responsible for the performance of the required maintenance listed in your owner’s manual. Distributor recommends that you retain all receipts covering maintenance on your vehicle, but Distributor cannot deny warranty solely for the lack of receipts or for your failure to ensure the performance of all scheduled maintenance.

You are responsible for presenting your vehicle to the Distributor dealer as soon as a problem exists. The warranty repairs should be completed in a reasonable amount of time, not to exceed 30 days.

As the vehicle owner, you should be aware that Distributor may deny your warranty coverage if your vehicle or a part has failed due to abuse, neglect, improper maintenance or unapproved modifications.

If you use your vehicle in any type of competitive event, this warranty is immediately and completely void.

If you have any questions regarding your warranty rights and responsibilities, you should contact distributor at 2848 Reward, Dallas, TX 75220, the U.S. Environmental Protection Agency, 2000 Traverwood Avenue, Ann Arbor, MI 48105 or, (for California registered off-road vehicles only) the California Air Resources Board at 9528 Telstar Avenue, El Monte, CA 91731.

BV Powersports, LLC – EMISSION CONTROL SYSTEM WARRANTY

YOUR WARRANTY RIGHTS AND OBLIGATIONS

BV Powersports, LLC (hereinafter “Distributor”) warrants that each new 2011 and later Distributor off-road vehicle:

A. is designed, built and equipped so as to conform at the time of initial retail purchase with all applicable regulations of the United States Environmental Protection Agency, and the California Air Resources Board; and

B. is free from defects in material and workmanship which cause such vehicle to fail to conform to applicable regulations of the United States Environmental Protection Agency or the California Air Resources Board for the periods specified above.

The warranty period begins on the date the vehicle is delivered to the initial retail purchaser, or on the date the vehicle is first placed in service as a demonstrator, rental, lease prior to retail sale.

I. Coverage. Warranty defects shall be remedied during customary business hours at any authorized Distributor dealer located within the United States of America in compliance with the Clean Air Act and applicable regulations of the United States Environmental Protection Agency and the California Air Resources Board. Any part or parts replaced under this warranty shall become the property of Distributor.

II. Limitations This Emission Control System Warranty shall not cover any of the following:

A. Repair or replacement as a result of

- (1) accident,
- (2) misuse,
- (3) repairs improperly performed or replacements improperly installed,
- (4) use of replacement parts or accessories not conforming to specifications set forth by Distributor, which adversely affect performance and/or
- (5) use in competitive racing or related events.

B. Inspections, replacement of parts and other services and adjustments required for required maintenance.

C. Any vehicle equipped with an odometer or hour meter on which the odometer mileage or hour meter reading has been changed so that actual mileage cannot be readily determined.

III. Limited Liability

A. The liability of Distributor under this Emission Control System Warranty is limited solely to the remedying of defects in material or workmanship by an authorized Distributor dealer at its place of business during customary business hours. This warranty does not cover inconvenience or loss of use of the vehicle or transportation of the vehicle to or from the Distributor or authorized dealer. Distributor shall not be liable for any other expenses, loss or damage, whether direct, incidental, consequential or exemplary arising in connection with the sale or use of or inability to use the distributor vehicle for any purpose. Some states do not allow the exclusion or limitation of any incidental or consequential damages, so the above limitations may not apply to you.

BV Powersports, LLC – EMISSION CONTROL SYSTEM WARRANTY

YOUR WARRANTY RIGHTS AND OBLIGATIONS

B. No express emission control system warranty is given by Distributor, except as specifically set forth herein. Any emission control system warranty implied by law, including any warranty of merchantability or fitness for a particular purpose, is limited to the express emission control system warranty terms stated in this warranty. The foregoing statements of warranty are exclusive and in lieu of all other remedies. Some states do not allow limitations on how long an implied warranty lasts, so the above limitations may not apply to you.

IV. LEGAL RIGHTS. This warranty gives you specific legal rights, and you may also have other rights which vary from state to state.

V. ADDITIONAL INFORMATION. Any replacement part that is equivalent in performance and durability may be used in the performance of any maintenance or repairs. However, distributor is not liable for these parts. The owner is responsible for the performance of all required maintenance. Such maintenance may be performed at a service establishment or by any individual.

This warranty is in addition to the Distributor limited vehicle warranty.

No dealer is authorized to modify this Limited Emission Control System Warranty issued by Distributor.

CONLENTS

OWNER'S MANUAL

Page

1.FOREWORD	1
2.AFEW WORDSABOUT SAFETY.....	2
3.IMPORTANT SAFETY INFORMATION.....	3
4.SAFETY LABELS	5
5.ARE YOU READYTO DRIVE?.....	6
6.IS YOUR VEHICLEREADY TODRIVE?	9
7.SAFE DRIVING PRECAUTIONS.....	10
8.REAY TO DVIVE	11
9.P.D.I.....	13
10.SPECIFICATIONS.....	14
11.OPERATION	16
12.SERVICE INSTRUCTIONS.....	22
13.REPAIR	26
14.MAINTENANCE TABLE.....	28
15.ELETRICITY PRINCIPLE DIAGRAM.....	29

PARTS MANUAL

CRANKCASE ASSY.....	26
CYLINDER HEADASSY.....	27
INTAKE EXHAUSTMECHANISM ASSY.....	28
BRANCE FLYINGWHEEL.....	29
CENTRIFUGAL ADJUSTMENTASSY.....	30
STARTING SETS.....	31
AIR CLEANERASSY.....	32
SWITCH ASSY,IGNITION.....	33
CARBURETOR SYSTEMASSY.....	35
STEERING SHAFTASSY.....	37
SUSPENSION ARM ASSY.....	39
REAR SWINGARM.....	40
REAR HOUSING.....	41
CLUTCH ASSY.....	43
WIRE HARNESS/ELECTRICAL/SEAT/ENGINE.....	45
WARNING STICKERSASSY.....	46

Thank you for purchasing our *TrailMaster* Go-kart MID. We hope you will enjoy it. Before you start to operate the *TrailMaster* Go-kart MID, please read through this Owner's Manual carefully as it contains important safety and maintenance information. Failure to follow the warnings contained in this manual can result in serious injuries or death.

Be sure to follow the recommended maintenance schedule and service your *TrailMaster* Go-kart MID accordingly. Preventive maintenance is extremely important to the longevity of your *TrailMaster* Go-kart MID.

Beginners should seek instructions from your dealer or qualified instructors before and during initial use of the *TrailMaster* Go-kart MID. It is also recommended to practice in a large open area and familiar with operations of this *TrailMaster* Go-kart MID.

We hope you will have a pleasant experience with our products and thanks again for choosing our *TrailMaster* Go-kart MID.

A FEW WORDS ABOUT SAFETY

In order to keep everyone safe, you must take responsibility for the safe operation of your *TrailMaster* Go-kart MID.

To help you make informed decisions about safety, we have provided operating procedures and other information on labels and in this manual. This information alerts you to potential hazards that could hurt you or others.

It is not practical or possible to warn you about all hazards associated with operating or maintaining a *TrailMaster* Go-kart MID. You must use your own good judgment.

You will find important safety information in a variety of forms, including:

Safety Labels - On the *TrailMaster* Go-kart MID.

Safety Messages - Preceded by a safety alert symbol  and one of two signal words: **WARNING**, or **CAUTION**.

These signal words mean:

WARNING

Physical harm may result from failure to adhere to the instructions that are described within the **WARNING** labels.

Safety Headings such as Important safety reminders or important safety precautions.

Safety Section - such as kart safety.

Instructions - how to use this *TrailMaster* Go-kart MID correctly and safely.

This entire manual is filled with important safety information, please read it carefully.

You *TrailMaster* Go-kart MID will provide you with many years of service and pleasure. The Safety Information will provide you to take responsibility for your own safety and understand the challenges you can meet while driving.

There is much that you can do to protect yourself while operating your *TrailMaster* Go-kart MID. You'll find many helpful recommendations throughout this manual. The following are a few points we consider most important for safety protection.

Follow the Age Recommendation

Adult supervision should be present for all people under the age of 13.

Always Wear a Helmet

Always wear an approved motorcycle helmet. We also recommend that you wear eye protection, sturdy boots, gloves, and other protective gear.

Drive Off-Road Only

Your *TrailMaster* Go-kart MID is designed and manufactured for off-road use only. The tires are not made for pavement, and the *TrailMaster* Go-kart MID does not have turn signals and other features required for use on public roads. If you need to cross a paved or public road, please get off and walk with your Go-kart across.

Take Time to Learn & Practice

Even if you have driven other Go-karts, take time to become familiar with how this *TrailMaster* Go-kart MID works and handles. Practice in a safe area until you build your skills and get accustomed to this Go-kart's size and weight.

Because many accidents involve inexperienced or untrained drivers, we urge all drivers to take a training course approved by the Go-kart Safety Institute. Check with your dealer for more information on training courses.

IMPORTANT SAFETY INFORMATION

Be Alert for Off-road Hazards

The terrain can present a variety of challenges when you drive off-road. Continually judge the terrain for unexpected turns, drop-offs, rocks, ruts and other hazards. Always keep your speed low enough to allow time to see and react to hazards.

Drive within your limits

Pushing limits is another major cause of *TrailMaster* Go-kart MID accidents. Never drive beyond your personal abilities or faster than conditions warrant. Remember that alcohol, drugs, fatigue and inattention can significantly reduce your ability to make good judgments and drive safely.

Don't drink and drive

Do not drive your *TrailMaster* Go-kart MID after drinking. Even one drink can reduce your ability to respond to changing conditions, and your reaction gets worse with every additional drink. So don't drink and drive, and don't let your friends drink and drive either.

Do not operate this *TrailMaster* Go-kart MID at night

Dark vision can greatly reduce a driver's visibility and judgment. So driving at night is dangerous and can increase the possibility for an accident.

Never run your *TrailMaster* Go-kart MID indoors

The exhaust from the engine contains a tasteless, odorless and poisonous gas called carbon monoxide.

Keep away from moving parts of the *TrailMaster* Go-kart MID

The operator of the *TrailMaster* Go-kart MID should never place their hands or other parts of their body near any moving part of the *TrailMaster* Go-kart MID. Failure to adhere to this warning will cause physical harm to your body.

Skidding or Sliding

The terrain surface can be a major factor affecting turns. Skidding in a turn is more likely to occur on slippery surfaces such as snow, ice, mud and loose gravel. If you skid on ice, you may lose all directional control. To avoid skidding on slippery terrain, keep your speed low and driving carefully.

SAFETY LABELS

This section presents some of most important information and recommendations to help you driving your *TrailMaster* Go-kart MID more safely. Please take some time to read this section.

The safety labels should be considered as permanent parts of the *TrailMaster* Go-kart MID becomes. If a safety label becomes hard to read, please contact your dealer for replacement.

 **WARNING**

3031112



- Moving parts can crush and cut.
- Keep hands clear.
- Do not operate with guard removed.

 WARNING	CAUTION
Seat Belt Must Be Worn AT All Times	THIS VEHICLE MANUFACTURED FOR OFF-ROAD USE ONLY. DO NOT OPERATE ON PUBLIC STREETS, ROADS OR HIGHWAYS.
3031105	



 **WARNING**

NO LONG HAIR



HAIR

ALL HAIR MUST BE TIED UP AND SECURED AT OR ABOVE SHOULDER LENGTH. ALL LOOSE CLOTHING MUST BE SECURED. ALL NECKLACES AND SCARVES MUST BE SECURED.

	 WARNING
	NORIDING

 **WARNING**

303115

THIS GO-KART CAN BE HAZARDOUS TO OPERATE if driven carelessly. INJURIES can result if you do not follow these Instructions:

- READ OWNER'S MANUAL AND ALL LABELS BEFORE YOU OPERATE THIS GO-KART.
- NEVER OPERATE THIS GO-KART WITHOUT PROPER INSTRUCTIONS. Beginners require mature supervision.
- NEVER OPERATE THIS GO-KART ON PUBLIC ROADS. It is intended off-road use only.
- NEVER OPERATE THIS GO-KART AT EXCESSIVE SPEEDS.
- NEVER ATTEMPT WHEELIES, JUMPS, OR OTHER STUNTS.

 **WARNING**

 This vehicle is not to be operated by anyone under 13 years of age. A speed reduction kit is available for this vehicle.

ARE YOU READY TO DRIVE?

Before each drive, you need to make sure that you and your Go-kart are ready to drive. To help you be prepared, this section discusses how to evaluate your driving readiness, what items you should check on your *TrailMaster* Go-kart MID, and which adjustments would be done for your comfort, convenience, and safety.

Before you drive this *TrailMaster* Go-kart MID for this first time, we urge you to:

- Read this owner's manual and the labels on your *TrailMaster* Go-kart MID carefully.
- Make sure you understand all the safety messages.
- Know how to operate all the controls.

Before each drive, be sure:

- You wear your seat belt at all times while driving your *TrailMaster* Go-kart MID.
- You feel well and are in good physical and mental condition.
- You are wearing an approved motorcycle helmet (with chin strap tightened securely), eye protection, and other protective clothing.
- You don't consume any alcohol or drug.

Protective Apparel

For your safety, we strongly recommend that you always wear a D.O.T. approved motorcycle helmet, eye protection, boots, gloves, long pants, and long-sleeved shirt or jacket whenever you drive.

Although complete protection is not possible, wearing proper gear can reduce the chance of injury by an accident.

The following suggestions will help you choose the proper protective gear.

Helmets and Eyes Protection

Your helmet is your most important piece of protective gear because it offers the best protection against head injuries. A helmet should fit your head comfortably and securely.

An open-face helmet offers some protection, but a full-face helmet offers more. Regardless of the style, look for a D.O.T. (Department of Transportation) sticker on any helmet you buy. Always wear a face shield or goggles to protect your eyes and help your vision.



WARNING

Operating this kart without wearing an approved motorcycle helmet, eye protection, and protective clothing could increase your chances of head and/or eye injury, and the possibility of death in the event of a severe accident.

Always wear an approved motorcycle helmet that fits properly and wear eye protection (goggles or face shield), gloves, boots, long-sleeved shirt or jacket and long pants.

ARE YOU READY TO DRIVE?

Additional Driving Gear

In addition to a helmet and eye protection, we also recommend:

- Sturdy off-road motorcycle boots to help protecting your feet, ankles, and lower legs.
- Off-road motorcycle gloves to help protecting your hands.
- Driving pants with knee and hip pads, a driving jersey with padded elbows, and a chest/shoulder protector.

Driver Training

Developing your driving skill is an on-going process. Even if you have driven other karts before, please take time to become familiar with how this kart works and handles. Practice driving this TrailMaster Go-kart MID in a safe area to develop your skills. Do not drive on rough terrain until you get accustomed to the kart's controls, and feel comfortable with its size and weight.



WARNING

Operating this kart without your seat belt could cause you to be thrown from the kart, causing serious injury or death.

No Alcohol or Drugs

Alcohol, drugs and karts don't mix. Even a small amount of alcohol can impair your ability to operate a kart safely. Likewise, drugs (even if it's prescribed by a physician) can be dangerous while operating a kart. Consult your doctor to be sure it is safe to operate a vehicle after taking medication.



WARNING

Operating this kart after consuming alcohol or drugs can seriously affect your judgment, cause you to react more slowly, affect your balance and perception, and could result in serious injury or death.

Never consume alcohol or drugs before or while operating this kart.

IS YOUR VEHICLE READY TO DRIVE?

Before each drive, it is important to inspect your kart and make sure any problems you find are corrected. Pre-drive inspection is a must, not only for safety, due to a break down or even a flat tire, can be a major inconvenience.

If your kart has overturned or has been involved in a collision, do not drive it until your kart has been inspected by your dealer. There may be damage or other problems that you can not see.



WARNING

Improperly maintaining this kart or failing to correct a problem before driving can cause a crash in which you can be seriously hurt or killed.

Always perform a pre-drive inspection before every drive and correct any problems.

SAFE DRIVING PRECAUTIONS

Off-Road Use Only

Your kart and its tires are designed and manufactured for off-road use only, not for use on paved surfaces. Driving on paved surfaces can affect the TrailMaster Go-kart MID handling and control.



WARNING

Operating this kart on paved surfaces may seriously affect handling and control of the kart, and may cause the vehicle to go out of control.

Never operate the kart on any paved surfaces, including sidewalks, driveways, parks lots and streets.

When driving off-road, also remember to always obey local off-road driving laws and regulations. Obtain permission to drive on private property. Avoid posted areas and obey no trespassing signs.

You should never drive your kart on public streets, roads or highways, even if they are not paved. Drivers of street vehicles may have difficulty seeing and avoiding you, which could lead to a collision.



WARNING

Operating this kart on public streets, roads or highways could cause a collision with another vehicle.

Never operate this kart on any public streets, roads or highways, whether they are dirt, gravel or paved surfaces.

Keep Hands and Feet on Controls

When driving your kart, always keep both hands on the steering wheel and both feet on the foot pedals. It is important to maintain your balance and to control the kart. Removing hands or feet away from the controls can reduce your ability to react and control the kart.



WARNING

Removing your hands from the steering wheel or feet from the foot controls during operation can reduce your ability to control the kart or could cause you to lose your balance and fall off the kart.

Always keep both hands on the steering wheel and both feet on the foot controls of your kart during operation.

Control Speed

Driving at excessive speed increases the chances of an accident. In choosing an appropriate speed, you need to consider the capability of your kart, the terrain, visibility and other operating conditions, plus your own skill and experience.



WARNING

Operating this kart at excessive speeds increases your chances of losing control of the kart, which can result in an accident.

Always drive at a speed that is appropriate for your kart, the terrain, visibility and other operating conditions, and your experience.

Use Kart on Unfamiliar or Rough Terrain

Before driving in a new area, always check the terrain thoroughly. Don't drive fast on unfamiliar terrain or when visibility is limited. (it's sometimes difficult to react in time if the obstructions like hidden rocks, bumps, or holes are seen too late.)



WARNING

Failure to use extra care when operating this kart on unfamiliar terrain could result in the kart overturning or going out of control.

Go slowly and be extra careful when operating on unfamiliar terrain. Always be alert to changing terrain conditions when operating the kart.

Never drive past the limit of visibility. Maintain a safe distance between your kart and other off-road vehicles. Always exercise caution and use extra care on rough, slippery and loose terrain.



WARNING

Failure to use extra care when operating on excessively rough, slippery or loose terrain could cause loss of traction or vehicle control, which could result in an accident, including an overturn.

Do not operate on excessively rough, slippery or loose terrain until you have learned and practiced the skills necessary to control the kart on such terrain.

Always be especially cautious on these kinds of terrain.

Do Not Perform Stunts

You should always operate your TrailMaster Go-kart MID in a safe and reasonable manner. When driving, always keep all four wheels on the ground.



WARNING

Attempting wheelies, jumps, and other stunts increases the chance of an accident, including an overturn.

Never attempt stunts, such as wheelies or jumps. Don't try to show off.

- A. Install rear shocks and tighten the nuts.
 - B. Install rod end, tie rod, tighten the castle nut and insert the cotter pin.
 - C. Install ball head dust seals, align the ball head bolt, knuckle support to the square hole on the lower A-Arm.
 - D. Install flange nut and tighten it (>88.9 foot lbs)
 - E. Install front tires and tighten the nuts.
 - F. Install rear tires, tighten the nuts, insert cotter pin and put on the rubber cover.
 - G. Raise the C.B.C custom bar cage as in picture.
 - H. Install C.B.C rear custom bar cage, put on R-Washer.
 - I. Install Head-Rest.
 - J. Check all nuts and bolts, wiring, cables, fuel line, switches and tire pressure.
 - K. Fill battery with acid and charge, check and fill the engine with the recommended oil.
- Fill fuel tank with unleaded gasoline, and turn on the ignition switch to start the engine.

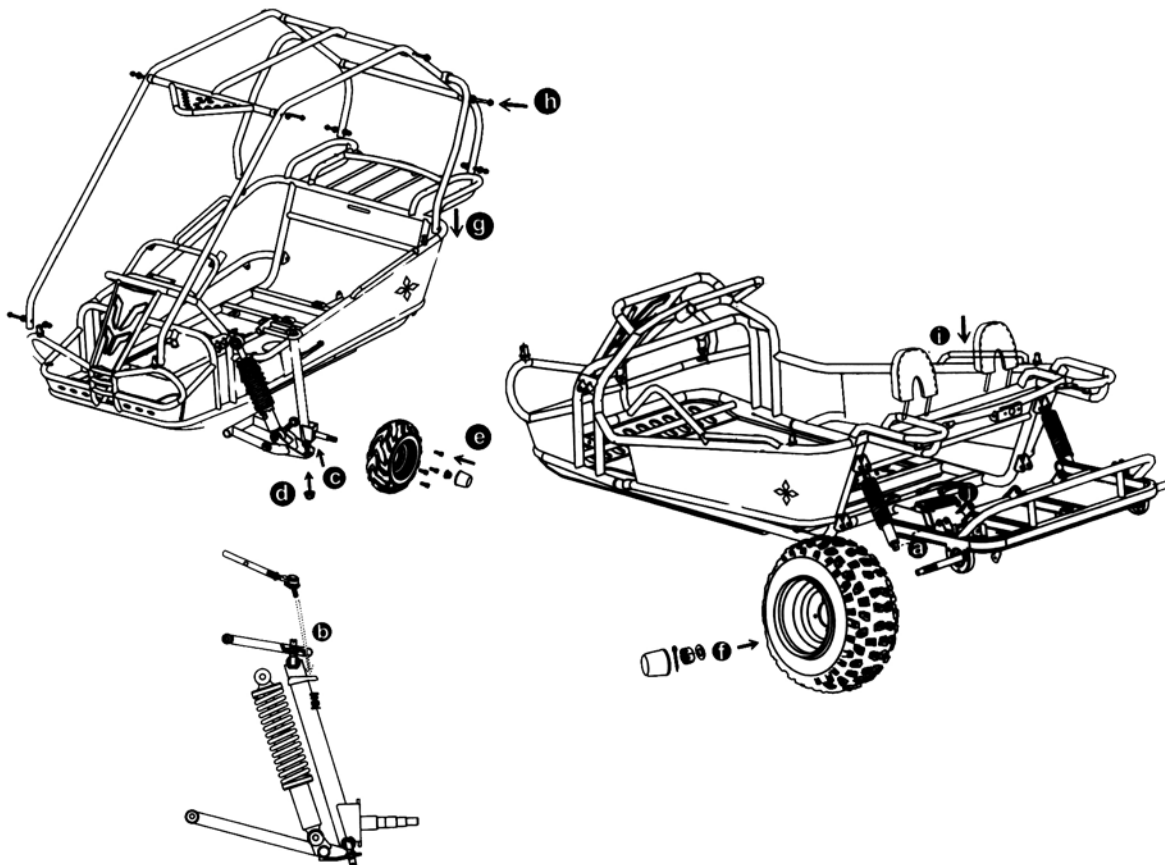

DIMENSIONS

Overall Length	58.5 in.(1700mm)
Overall Width	36 in.(1100mm)
Overall Height	43 in.(1300mm)
Wheelbase	41.7 in.(1230mm)
Front Track	32 in.(930mm)
Rear Track	28 in.(850mm)
Ground Clearance	3.5 in.(70mm)

ENGINE

Type	Single, Forced air-cooled, 4-Stroke
Engine capacity	168cc
Bore x Stroke	2.67in x 2.1in
Displacement	196ml
Corrected compression ratio	8:1
Carburetor	RX
Output Power	6.3 HP at 3600RPM
Maximum Torque	9.6 lb ft at 2500RPM
Starting	Electric / Pull start backup
Ignition	C.D.I
Lubrication	Force & Splash
Transmission	Automatic (C.V.T system)
Spark Plug	F7RTC
Plug gap	0.7-0.8mm
Fuel Type	Rq 90
Lubricate oil	SAE 10W/30

CAPACITIES

Maximum load	Double Seats / 400lbs
Fuel tank	0.95gal
Engine oil	3Oz
Starting	<5s
Battery	12V 9Ah
Fuse	10A
Brake Track	<7m@10miles/h
Top speed	25 mph (or limited as customers require)

SPECIFICATIONS

CHASSIS

Rear brake····· Disc brake
Front tire·····16 x 6-8
Rear tire·····16 x 7-8
Front Suspension·····Independent Dual A-Arm
Rear Suspension·····Swing Arm / Double Oil Damped Shock
Restraint System·····Dual 4-point Harness

TIRE PRESSURE

Front·····7~9psi
Rear·····7~9psi

WEIGHT

Net Weight 150Kg

PACKING DIMENSIONS

Dimensions·····66.9in x 43.3in x 25.9in
N.W·····330lbs
G.W·····385lbs
Loading quantity·····54pcs / 1 x 40ft HQ

A. Operation controls

WARNING - Do not attempt to start or operate the engine until completely familiar with the location and use of each control necessary to operate this vehicle. The operator must know how to stop this machine before starting and driving it.

a. Throttle

The right foot pedal is the throttle that controls the kart speed. As the engine speed increases above idle, the clutch is engaged automatically and moves the vehicle forward. To disengage the clutch at any time, allow the throttle to return to the idle position. (See Fig. 1)

NOTICE

Each time prior to starting the engine, check the throttle assembly to ensure that when the pedal is pushed all the way forward the assembly is working smoothly and returns to idle when released. Do not operate if pedal or engine throttle linkage fail to return to idle. If unable to correct the problem through lubrication, adjustment or replacement of worn parts, contact your dealer for assistance.

b. Brake

The brake is the left foot pedal (See Fig.1). Applying pressure to the pedal draws the brake caliper around the brake disc at the rear wheel and slows stop the kart.

c. Start Engine

Insert the key into key-switch, turn the key clockwise, release the key when the engine starts. The engine will warm within 5 minutes and the engine choke will close automatically and run at normal RPM (Warning: Do not crank starter more than 5 seconds at one time).

Remark: the TrailMaster Go-kart MID basic version XRS has also variant model without electric start function. Only pull start.

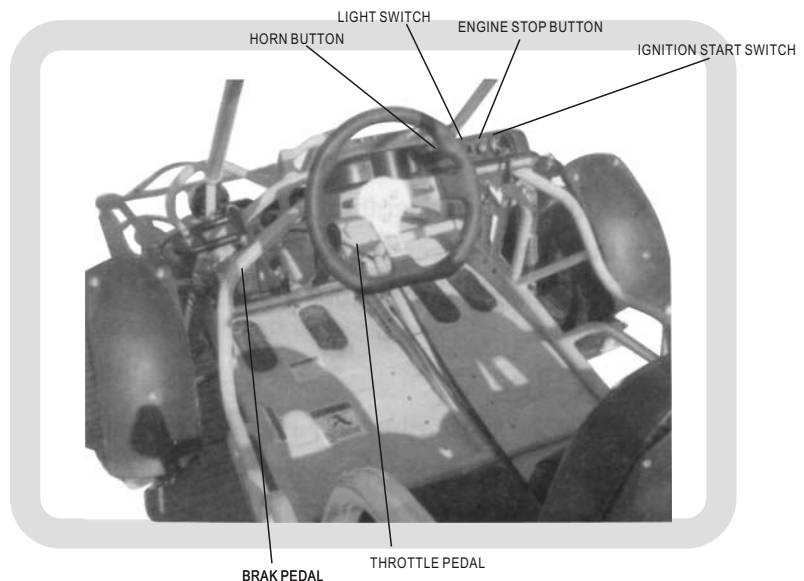

Figure 1 front panel

d. Engine stop button

Before driving this vehicle, test the Engine Stop Button to ensure that it is operating properly. With the engine running, push and hold the Engine Stop Button for two seconds until the engine has been shut down.

B. Pre-Drive Inspection



Perform this pre-drive inspection everyday before driving the vehicle. If not performed, serious damage to the vehicle or personal injury may result.

- a) Check the engine oil level is between the bottom of the dipstick and the “0” mark.
- b) Check for leaks. Add oil if required.
- c) Check the Fuel Level. Add fuel as necessary and do not overfill.
- d) Check for leaks. Ensure the fuel filler cap is securely fastened.
- e) Check the Brakes. Depress the left brake pedal several times, and check for adequate brake pedal free play. Make sure there is no brake fluid leakage.
- f) Check the tires. Check their condition for damage or excessive wear and pressure. The pressure on the front and rear tires is 7-9 psi respectively.
- g) Check the drive chain. Check its condition and tension. Lubricate if necessary.
- h) Check the throttle cable; check its smooth operation. Ensure the throttle can return back to idle and move smoothly without sticking by releasing the throttle pedal.
- i) Check the Engine Stop Button. While the engine is running press and hold the engine stop button for 2 seconds. Make sure the engine stops.
- j) Check all nuts, bolts, and fasteners.
- k) Check the wheels to see that all axle nuts and lug nuts are tightened properly. Check and tighten as necessary all other nuts, bolts and fasteners.
- l) Check the Brush Guard. Ensure all C.B.C bars are in place before operating the kart.
- m) Check the Lights. Check the headlights, brake light and tail light are all working.
- n) Check the steering system. Check that the steering wheel moves freely in both directions but without any unusual looseness.
- o) Check all Cable Housings. Check these for wear and the fitting for any looseness.
- p)

Check the underbody and exhaust system. Remove all dirt, vegetation and mud and check any damage due to impact with rocks or uneven terrain.

- q) Check the air cleaner housing drain tube. Check the deposits in the drain tube. If necessary, check the tube and air cleaner housing.
- r) Check leaks and loose parts. Walk around your kart and look for anything that appears unusual, such as a leak or loose cable.
- s) Check the parking brake. Make sure the kart does not move forward or backward when the parking brake is applied.

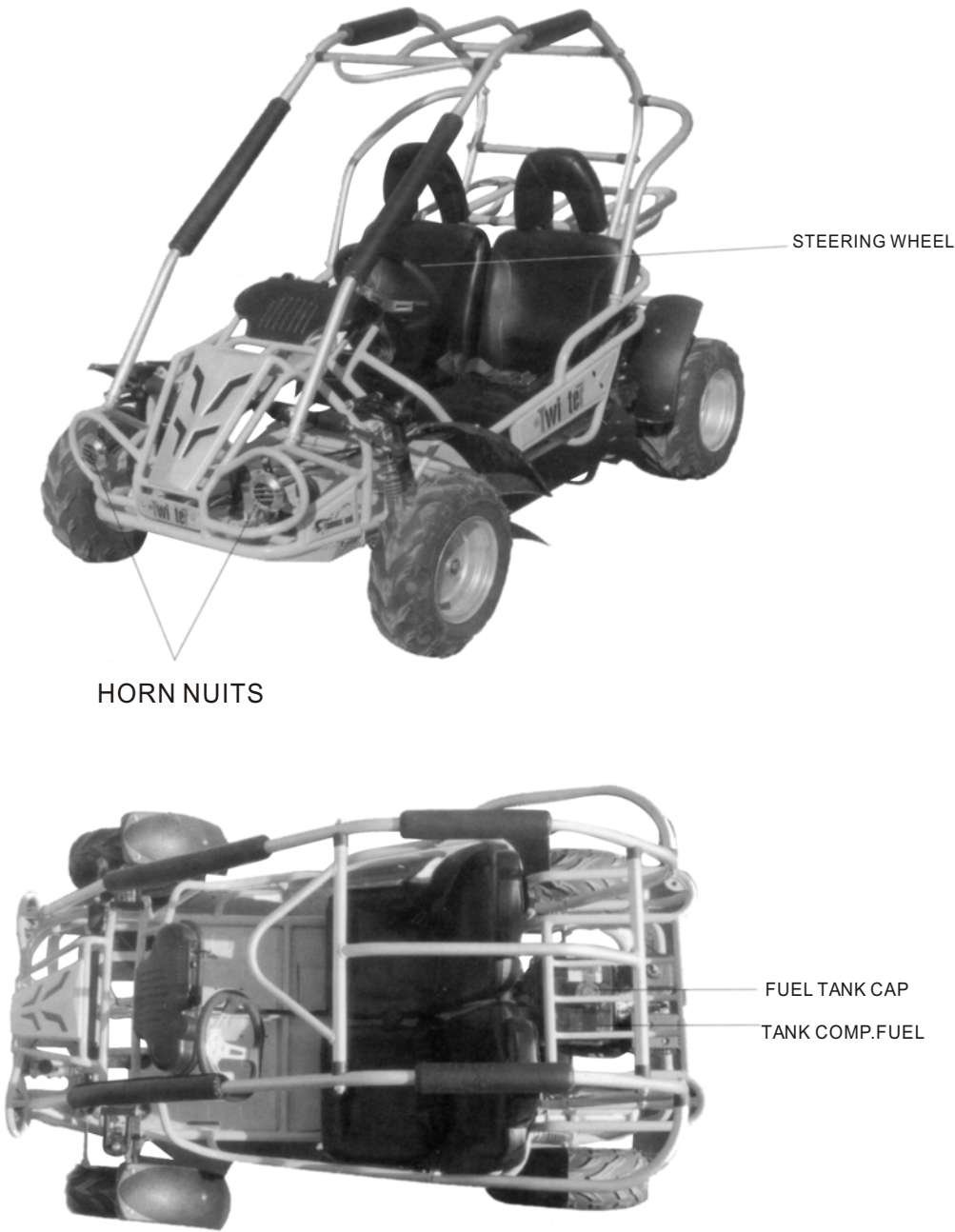

Figure 2 Component locations

OPERATION

C. Passengers

The vehicle is designed for two people only. The combined maximum weight of the driver and the passenger should not exceed 180kg or 400lbs. (Remark: Different versions of *TrailMaster* Go-kart MID could have different seats design.)

D. Seat Adjustment

The seat should be securely fastened in the position which gives the operator best control of the foot pedals, steering wheel, and the engine stop button.

- a. Pull the seat adjustment handle upward to disengage the seat slide.
- b. Move the seat to the desired position.
- c. Be sure that the seat adjustment handle snaps back into place and that seat is locked into position.



Figure 3 seats



WARNING

Before attempting to adjust the seat, ensure that engine is stopped



WARNING

Never operate this kart when the seat is not securely in place, to do so could result in personal injury or loss of life.

E. Starting and Operating Instructions

- a. Before starting the engine, the driver must seat properly in the kart with the seat belt on.
- b. Practice in the kart in an open space at the beginning to learn how to start, turn and stop the kart.
- c. Drive slowly until you are familiar with the operation of the TrailMaster Go-kart MID.
- d. The turning radius of this kart is small and agile, so the centrifugal force is very high when turning at high speed. Slow down to a more controllable speed when turning to prevent the kart from rolling over. The driver should keep their heels on the ramp of the main board when turning. Keeping their legs on the foot pedal (See Fig.4), the driver can feel that the kart is stable and won't roll over.

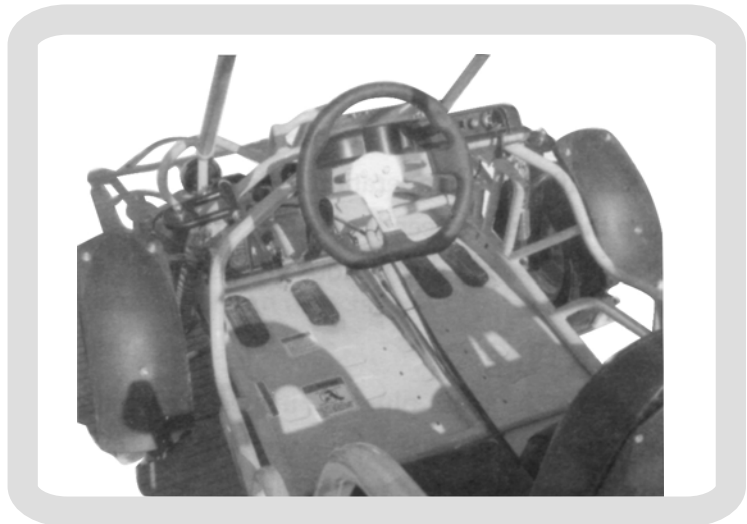

Figure 4 Heels and legs position by driving the kart

SERVICE INSTRUCTIONS

A. Engine Lubrication

You must change the oil in the crankcase after the first 5 hours of operating of your new engine (See Fig.6) and after every 10 hours of use thereafter. This will insure proper lubrication of the internal parts and prevent costly repairs due to excessive wear.



a. Remove the drain plug located on the right rear side of engine. Tip the kart backwards slightly by blocking up the front end and drain the oil into suitable container.

b. Remove and clean the oil filter.

c. Replace drain plug and tighten securely. Place the kart in a level position.

d. Refill the crankcase (approximately 1 1/4 pint) to the top of the filler neck with SAE 10W40 oil.

e. Check the oil level before each use of the kart or after each 10 hours of operation. Add oil when necessary to keep the level between the bottom of the dipstick and the □0□ mark. Do not mix various grades of oil.

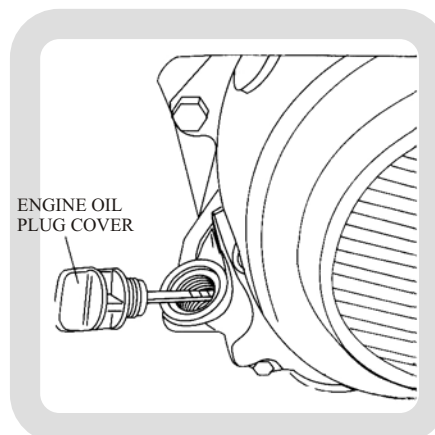

Figure 5 Engine oil plug cover

B. Spark Plug

a. Remove the spark plug and inspect it each time you change the oil (use a spark plug wrench).The electrodes should be kept clean and free of carbon. The presence of carbon or excess oil will greatly reduce engine performance. If possible, check the spark plug gap (area between electrodes)using a wire feeler gauge. This specification is 0.7-0.8 mm.

b. Before installing the spark plug coat the threads lightly with graphite grease if possible, to ensure easy removal next time the spark plug needs Inspection.

c. It is advisable to replace the spark plug at least once a year to ensure easy starting and good engine performance.

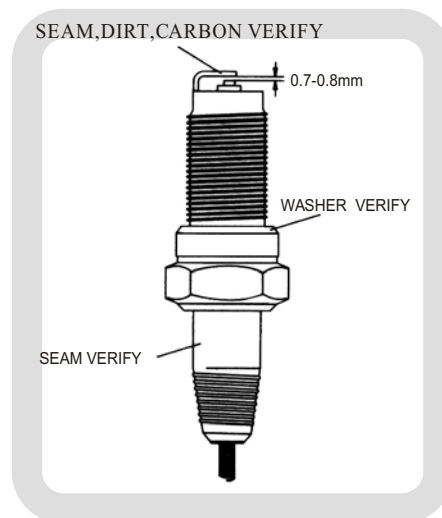

Figure 6 Spark plug

C. Adjusting the throttle and idle speed

- a) Warm up the engine (5-10min)
- b) Tighten the air screw gently. Back out 2-3/8 turns counter clockwise.
- c) Connect the tachometer, adjust the throttle to limit the idle speed. The standard value is 1400RPM.
- d) Turn the air screw counter clockwise slowly and observe the RPM of the engine, stop adjusting as the RPM reaches the top speed
- e) Adjust the screw and adjust the idle speed to an ideal value.
- f) Recheck and readjust the idle speed if necessary.

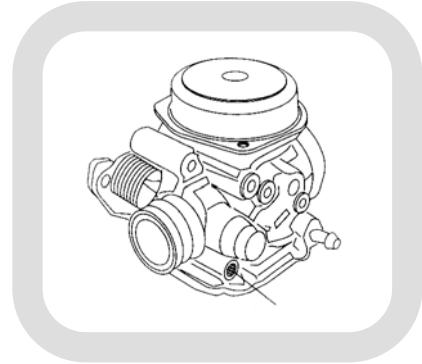

Figure 7 adjusting the throttle

D. Cleaning Instructions

Keep your kart clean. With a clean rag, wipe off all dirt and oil from around the controls. Wipe off any spilled fuel and oil. Keep the engine clean of foreign objects, and be sure to check that the air intake fan is free of debris for proper cooling.

E. Go-kart Lubrication

Lubricate this TrailMaster Go-kart MID every 90 days of use. Lubrication should be done more often, if the kart is used everyday.

F. Chain Lubrication

To increase chain life it should be lubricated with a spray on type chain lubricant. (See Fig.8)

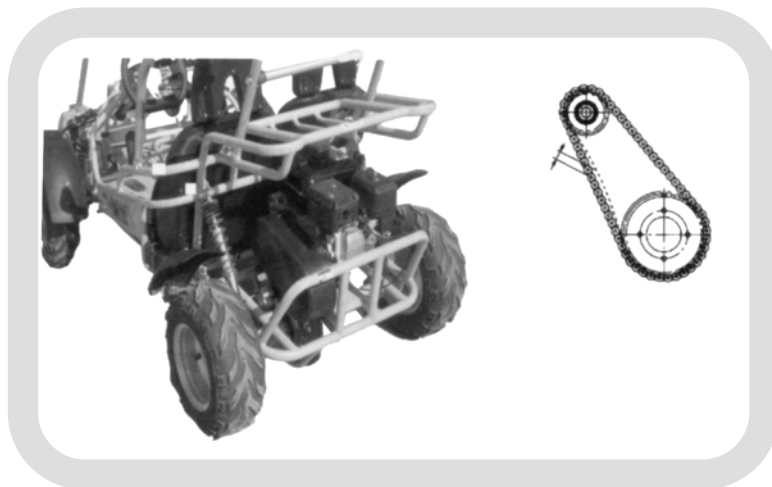

Figure 8 Drive chain lubrication

SERVICE INSTRUCTIONS

G. Adjustment of front and rear shock

There are five adjustable positions on each shock. The default position is in the middle set by manufacturer (See Fig.9)

Use a round nut wrench as you adjust the shock, the tension of shock spring will increase as you screw to left, decrease as you screw to right. Adjustment is according to the weight of the riders.

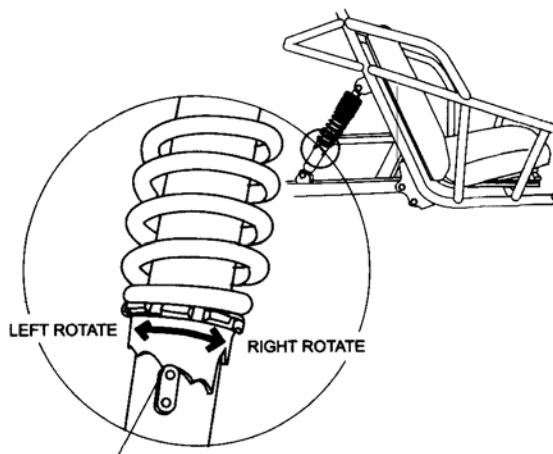

Figure 9 Shock adjustment

H. Storage instruction

In the event your TrailMaster Go-kart MID is not to be operated for period in excess of 30 days or at the end of each driving season prepare for storage as follows:

- a. Drain fuel tank and carburetor by allowing engine to run out of fuel, and use a fuel stabilizer.
- b. Lubricate engine cylinder by removing the air cleaner, then spray engine fogging oil through the carburetor until the motor dies.
- c. Do not save or store gasoline over winter. Using old gasoline, which has deteriorated from storage, will make the engine difficult to start and affect engine performance.

WARNING

Do not drain fuel while engine is hot. Be sure to move the kart outside before draining fuel.

A. Front Wheel Replacement

Do not disassemble the castle nuts when you replace the front wheels. It's only necessary to remove the 4 nuts to disassemble the wheel. (See Fig.10) Tighten the nuts after replacing the wheels.

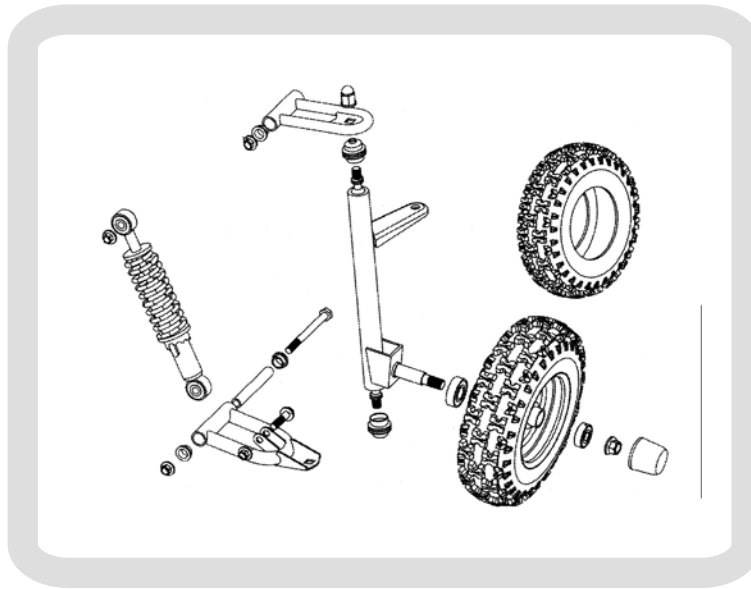

Figure 10 Replace the front wheel

B. Rear wheel replacement

Do not disassemble the castle nuts when you replace the rear wheels and hub assembly. Remove the cotter pin and then 24 mm nut. After that slide off the wheel and hub assembly. It is only necessary to remove the 4 nuts to remove the wheel. (See Fig.11)

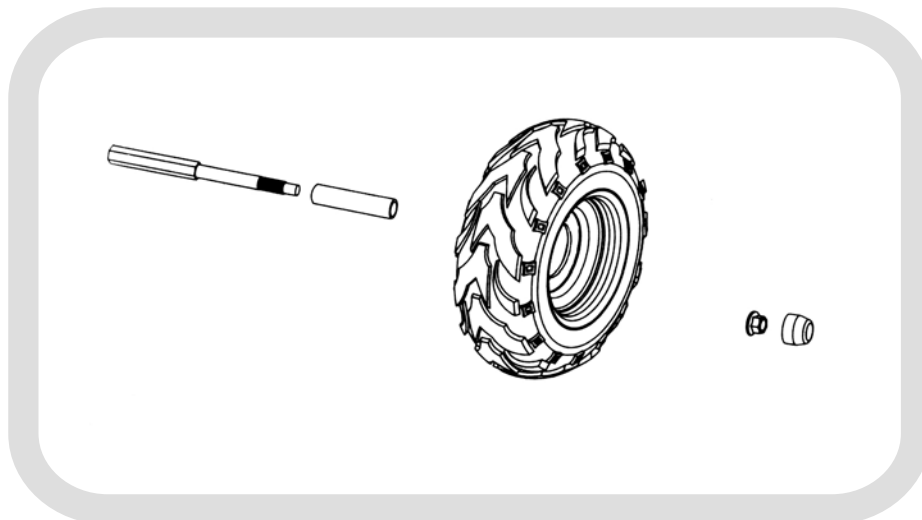

Figure 11 Replace the rear wheel

C. Front Wheel Alignment

a. The front wheels should be toe in from 1/8 to 1/4 inch. Measure the distance A and B between the centerline (CL) of the wheels to check for alignment. The proper toe in dimension A should be 1/8 -1/4 inch greater than dimension B.

b. To adjust the alignment, loosen the lock nuts on both sides of front tie rod. To make Dimension B smaller, turn the rod to left. Adjust the rod to right direction to make Dimension B larger. After adjusting to the desired length, tighten the lock nut against the rod end. Recheck the dimensions for proper alignment.

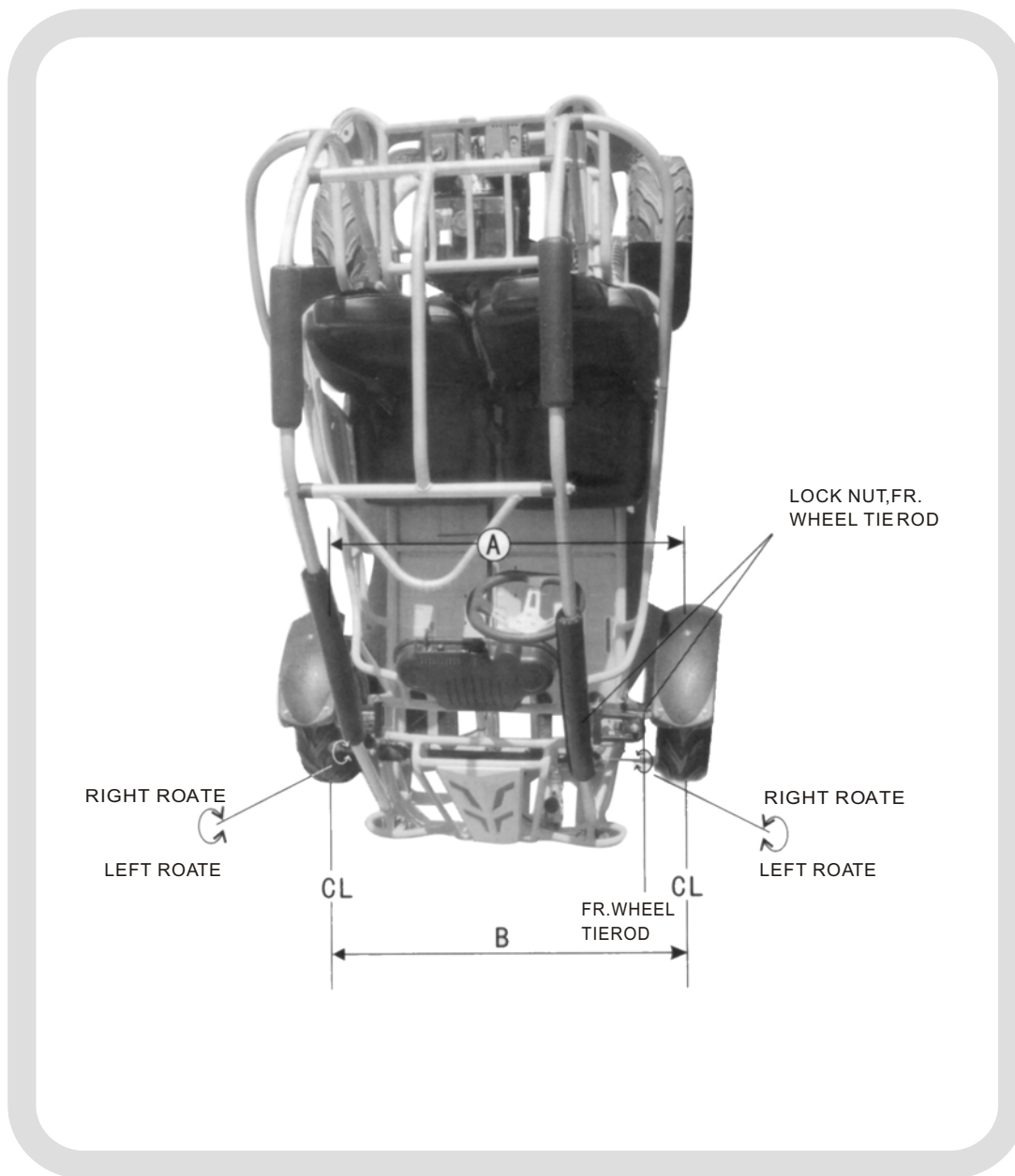

Figure 12 Front wheel alignment

MAINTENANCE TABLE

To keep the performance good, the motorcycle should be checked and maintained at certain interval. The meanings of capital in following table are:

I: Inspection, including check, clean, lubricate, refuel, repair or replacing if necessary.

A: Adjusting C: Cleaning R: Replacing T: Tightening

Maintenance period Items	Odometer (km)													
	300	1000	2000	3000	4000	5000	6000	7000	8000	9000	10000	11000	12000	Everyday check before riding
Engine oil	R	R		R	R	R		R			R		R	I
Air filter	Clean filter every 2000~3000 km. change it when necessary													
Spark plug	Initial 1000km and Clean every 3000~4000km change it when necessary													
Valve gap		A			A				A					A
Carburetor	I				I,C				I,C					I,C
Gas filter									R					
Brake system		I	I	I	I	I	I	I	I	I	I	I	I	I
Driving chain		I							I					I
Fasteners						T					T			
Bat tery													I	

* When the mileage is over the highest on the table, please perform according to the period set on the table

* Driving on dust place, it is recommended to clean it frequently.

ELECTRICITY PRINCIPLE DIAGRAM

ELECTRICITY PRINCIPLE DIAGRAM

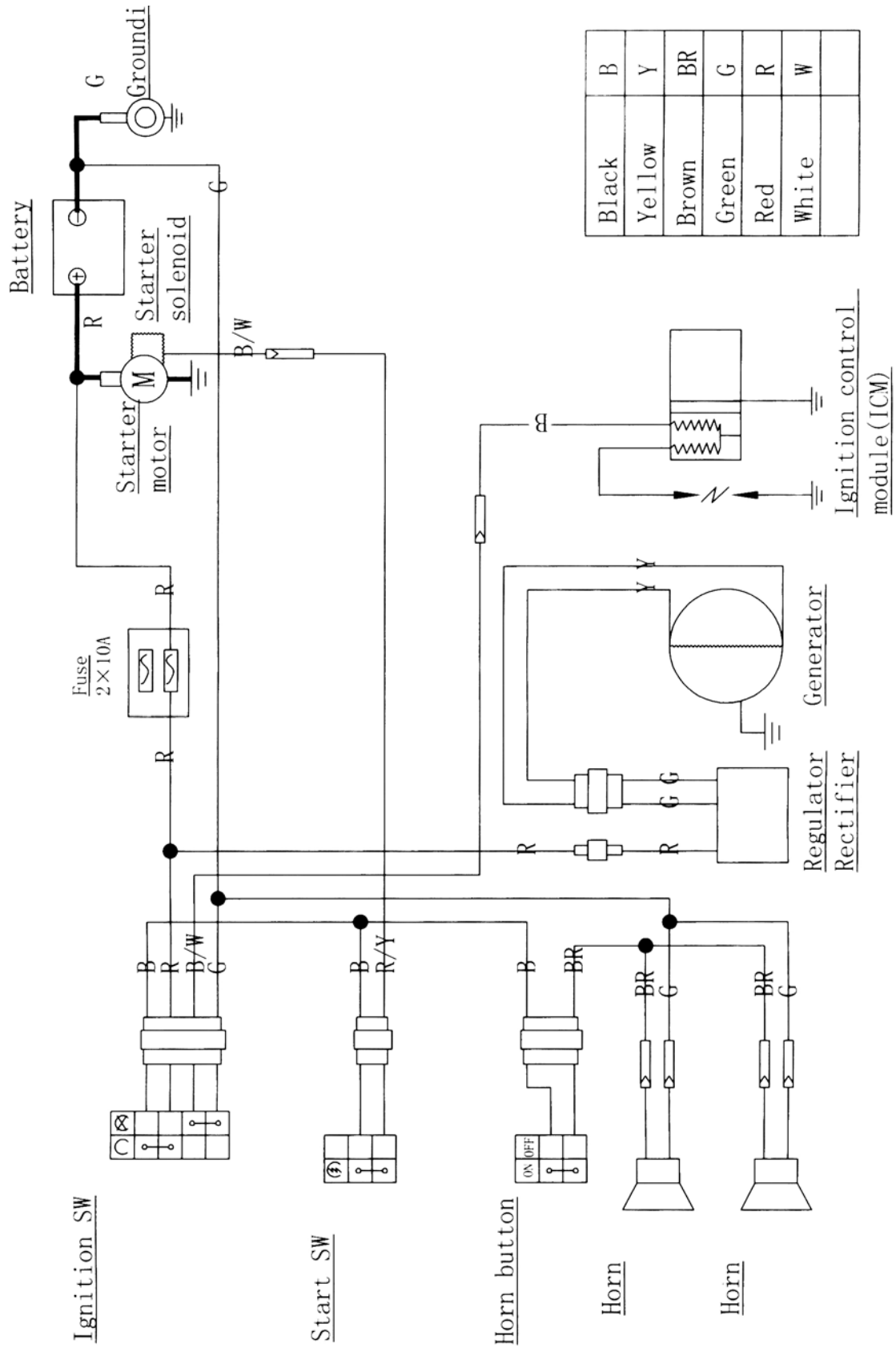

ELECTRICITY PRINCIPLE DIAGRAM

